

ULTIMATE LMC SERIES

Semi automatic L sealer packaging machine



Ultimate[®] is a registered trademark of PackPark

ULTIMATE LMC SERIES

Semi automatic L sealer packaging machine

ADVANTAGES

- Practical semi-automatic solution for low and medium capacity requirements
- Easy to use, compatible with health and safety standards
- Ability to provide heat to wire at exact efficient dose, realized by I-Sealing System®
- Ability to keep wire temperature constant, realized by I-Sealing System®
- Increase in sealing quality, process accuracy and life-span by stabilized heat control

FEATURES

- M Series: Sealing L-Bar is driven by a motor (no need for compressed air)
- M Series: In automatic mode, sealing bar cycles automatically in predefined period
- M Series: In free mode, sealing bar is triggered by button
- M Series: Sensor detects any obstacle and stops the cycle automatically for safety
- H Series: Sealing L-Bar is closed by hand, weight is balanced with reverse load
- H Series: Magnetic holder keeps L-Bar closed for pre-defined time period
- Easy to integrate with all types of heat tunnel directly
- Products are discharged by internal belt conveyor automatically
- Operated by digital control panel
- Position of the working table can be adjusted with respect to product width
- Single-axis film roll holding profile can be easily removed, replaced and fixed
- Easily transportable on wheels inside a facility

SEALING

- M Series: Sealing is actuated by motor in between wire and silicon rubber
- H Series: Sealing is actuated manually in between wire and silicon rubber
- Sealing wire is positioned on fixed bottom frame for safety
- Sealing wire is embedded into heat-resistant fiber profile
- Teflon belt covered silicon rubber increase sealing quality and life-span of silicon

FLEXIBILITY

- Discharge belt height can be adjusted with respect to varying product height
- Discharge belt working time can be adjusted with respect to varying product length
- Power of sealing wire can be adjusted with respect to varying film thicknesses
- Heat, time and speed parameters can be easily adjusted via digital control panel
- Various language options are available in digital control panel
- Detailed technical menu is available in digital control panel

OPTIONAL

- Automatic trim winder option is available upon request
- Stainless steel versions are available for wet/moist working environment
- Heat treated strong wooden case is available for risky transport conditions
- On-site installation and training service options are available

QUALITY

- ISO9001 quality standards with the relevant norm's confirmation
- CE certifications, complies with the latest CE directives
- World-wide approved brands for all mechanical and electrical components
- 1 year warranty against manufacturing faults
- Wearable parts are not included in warranty terms
- 1 set of wear parts is provided along with the machine
- 5 years spare part stock availability is provided
- Installation, testing and training services are provided free of charge



Technical Specifications

Sealer Bar Opening: 250mm
Maximum Capacity: 10 - 15 pack/min. *
Maximum Product Height: 245mm
Maximum Roll Diameter: 250mm
Working Height: 860mm
Compr. Air Supply: No
Film Types: POF: 7-37 mic. PVC: 15-25 mic.
Color: Mixed grey + RAL7010 + RAL7015

LMC 58x44-H

Working Principle: Close with hand
L - Sealer Sizes: 580 x 440mm
Maximum Film Width: 550mm
Installed Power: 400V 5A 3 phase
Average Consumption: 2 kW / 1,4 kW
Dimensions (AxBxC): 760x1500x1200mm
Palletized Size (AxBxC): 950x1700x1250mm
Weight (Net / Gross): 144 kg / 161 kg

LMC 80x65-H

Close with hand
800 x 650mm
680mm
400V 6A 3 phase
2,4 kW / 1,8 kW
1100x2050x1200mm
1300x2250x1250mm
196 kg / 219 kg

LMC58x44-M

Motorized
580 x 440mm
550mm
400V 5A 3 phase
2 kW / 1,4 kW
760x1500x1200mm
950x1700x1250mm
148 kg / 166 kg

LMC 80x65-M

Motorized
800 x 650mm
680mm
400V 6A 3 faz
2,4 kW / 1,8 kW
1100x2050x1200mm
1300x2250x1250mm
201 kg / 226 kg

LMC 95x65-M

Motorized
950 x 650mm
680mm
400V 6A 3 phase
2,6 kW / 2 kW
1100x2260x1200mm
1300x2600x1250mm
217 kg / 243 kg

* For DIN A4 form and LMC Series servo real working speed depends on the product dimensions and the film type.

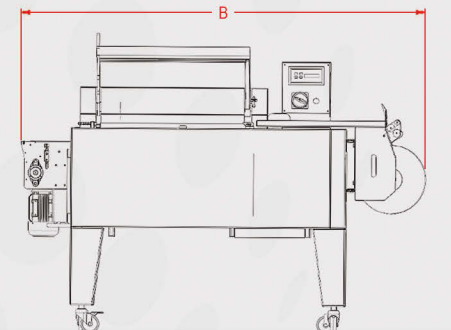
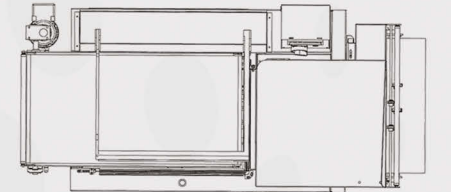
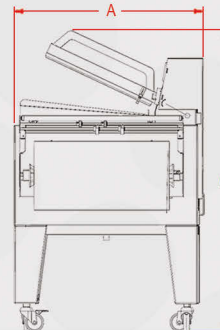
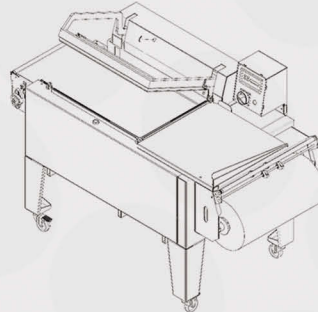

Park Endüstriyel Ürünler Sanayi Uluslararası İç ve Dış Tic. Ltd. Şti.
Atalar Cad. Gamze Sk. No: 13/A 34862
Atalar / Kartal / İstanbul / Türkiye
Tel: +90 216 353 54 66 Mobile / WhatsApp: +90 533 690 05 55
info@packpark.com.tr www.packpark.com.tr