

ULTIMATE SYMPACK SERIES

Fully automated continuous sealer and tunnel combination



Ultimate[®] is a registered trademark of PackPark

ULTIMATE SYMPACK SERIES

Fully automated continuous sealer and tunnel combination

ADVANTAGES

- Minimized layout requirement by compact and esthetic single-chassis design
- The optimum automatic solution for above average capacity processes
- Continuous side sealer provides unlimited length packaging ability
- Very fast and flawless sealing property by Servo driven vertical sealer
- Easy to integrate with the production lines directly
- Recordable and re-callable temperature and position adjustments

FEATURES

- Automatic length detection by sensor synchronized with encoder control
- User-friendly colorful touch screen operator panel
- Automatic packaging film drive with tension control
- Automatic trim winder with tension control
- Automatic post cooling mechanism for cooling down to 70°C before switch off
- Additional emergency temperature control system against fire risk
- Feeding frequency control by sensor detection and PLC command
- Ability to read instant (or total) realized capacity by counter
- Strong needle-wheel frame structure for air discharge perforation
- Reduced energy consumption and increased esthetic look by Diamond design
- Adjustable speed of tunnel conveyor for optimized heat application period
- Heat adjustment with digital PID control
- Air circulation control by side flap handles

SEALING

- Center-Seal property provides accurate and linear sealing line
- Adjustable precision and pressure on cutting and sealing force
- PID controlled sealing temperature inserted by touch panel
- Alternative sealing blade structures for various packaging material
- Product clearance control under seal bar by sensor

FLEXIBILITY

- Easily adjustable for varying product sizes and capacity requirements
- Various language options and adaptable touch keyboard
- Memory Receipt property for prompt adjustments
- Experienced design of sealing blade compatible with broad range of thickness
- User friendly designed trim-winder for easy and prompt trim unloading
- Less layout space requirement by embedded easy-to-open film roll drawer

OPTIONAL

- Solenoid actuator for side sealer: Free of compressed air requirement
- Ability to control additional conveyors by inverters
- Chain lift-up system to easily switch in between PE/POF material
- Tunnel conveyor alternatives: Wire Mesh, Teflon Mesh or Plastic Mesh

QUALITY

- ISO9001 quality standards with the relevant norm's confirmation
- World-wide brands for all mechanical, electrical and pneumatic components
- CE certifications, complies with the latest CE directives
- One year warranty on non-wearable parts (extendable)
- Manufacturer's guarantee for spare part stock and after sales support
- Manufacturer's guarantee for spare part stock availability up to 5 years



Technical Specifications

Maximum Packaging Size: W:650 L:300 H:200mm (26x12x8")	Minimum Package Width: 50mm (2")	Air Supply: 6 Bar
Sealer Opening: 200mm (8")	Maximum Film Width: 550mm (22")	Installed Power: 400v - 3 phase, 20A, 13kW
Conveyor Speed: 0-30 mt/min. (adjustment)	Film Thickness: 15-60 micron	Average Consumption: 8 - 10 kW
Cross Sealer Length: 420mm (17")	Film Types: POF, PE, PVC	Dimensions (Width/Length/Height): 1500x2800x1550mm (59x110x61")
Working Height: 855mm (+50mm) (34")	Maximum Roll Diameter: Ø 270mm (11")	Palletized Size (Width/Length/Height): 1700x3000x1750mm (67x118x69")
Conveyor Belt Width: 350mm (14")	Color: Mixed grey + RAL7015 + RAL7010	Weight (Net / Gross): 690 kg / 810 kg (1521 lbs / 1786 lbs)

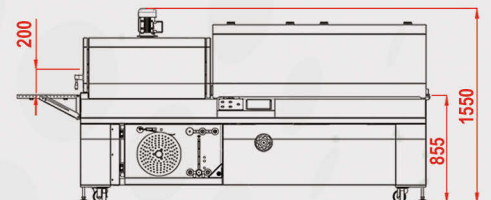
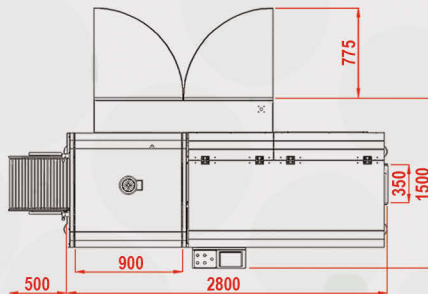
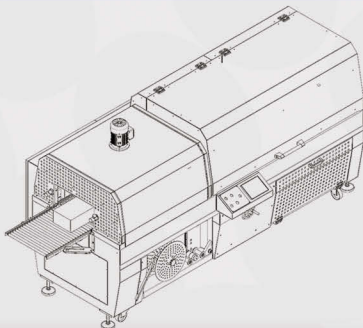

Park Endüstriyel Ürünler Sanayi Uluslararası İç ve Dış Tic. Ltd. Şti.
Atalar Cad. Gamze Sk. No: 13/A 34862
Atalar / Kartal / İstanbul / Türkiye
Tel: +90 216 353 54 66 Mobile / WhatsApp: +90 533 690 05 55
info@packpark.com.tr www.packpark.com.tr